

BUS-CONTROLLED VIDEO MATRIX SWITCH

- 15MHz BANDWIDTH
- CASCADABLE WITH ANOTHER TEA6415B (INTERNAL ADDRESS CAN BE CHANGED BY PIN 7 VOLTAGE)
- 8 INPUTS (CVBS, RGB, MAC, CHROMA...)
- 6 OUTPUTS
- POSSIBILITY OF MAC OR CHROMA SIGNAL FOR EACH INPUT BY SWITCHING-OFF THE CLAMP WITH AN EXTERNAL RESISTOR BRIDGE
- BUS CONTROLLED
- 6.5dB GAIN BETWEEN ANY INPUT AND OUTPUT
- - 50dB CROSSTALK AT 5 MHz
- FULLY ESD PROTECTED

DESCRIPTION

The main function of the TEA6415B is to switch 8 video input sources on the 6 outputs.

Each output can be switched to only one of the inputs whereas but any same input may be connected to several outputs.

All the switching possibilities are controlled through the I²C Bus.

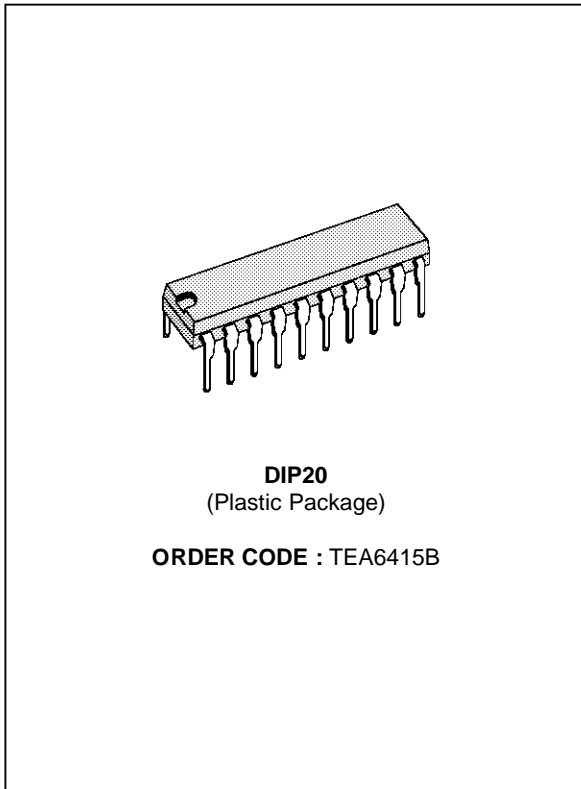

PIN CONNECTIONS

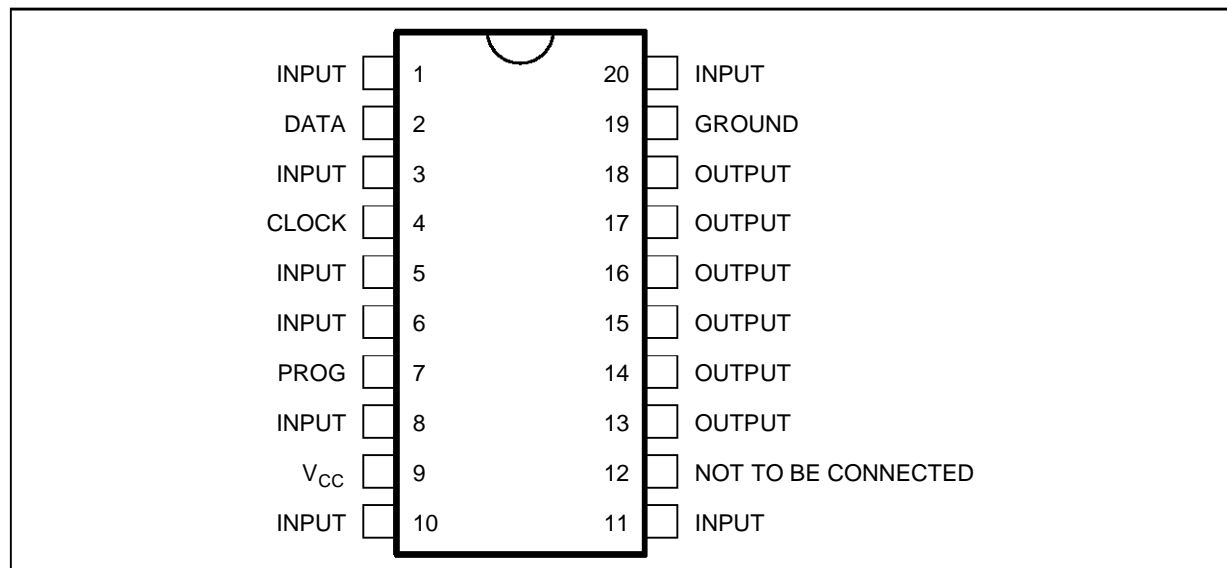

6415B-01.EPS

BLOCK DIAGRAM

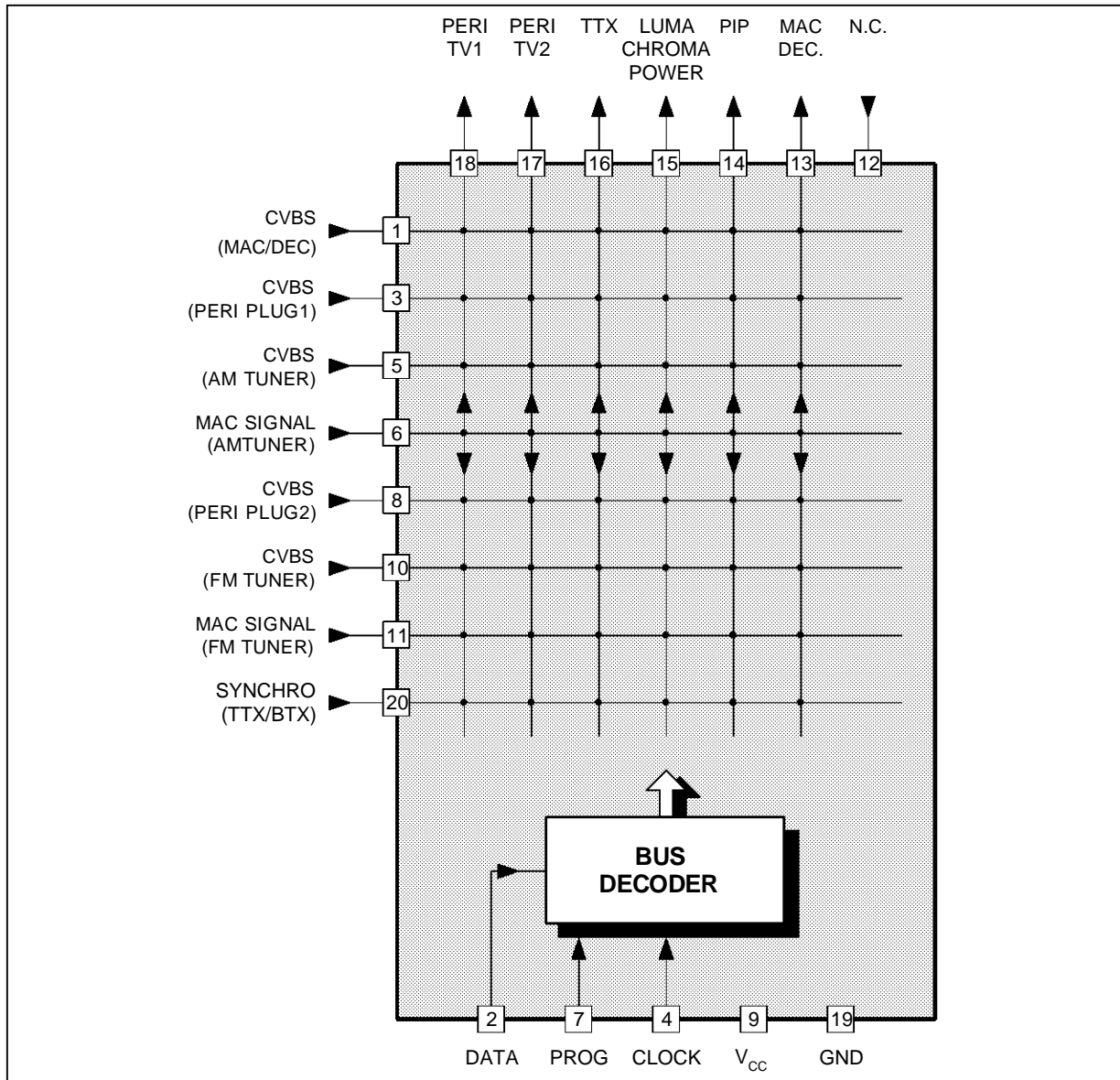

6415B-02.EPS

ABSOLUTE MAXIMUM RATINGS

Symbol	Parameter	Value	Unit
V_{CC}	Supply Voltage (pin 9)	13	V
T_A	Operating Ambient Temperature Range	0 to +70	°C
T_{stg}	Storage Temperature Range	-20 to +150	°C

6415B-01.TBL

THERMAL DATA

Symbol	Parameter	Min.	Typ.
$R_{th(j-a)}$	Junction-Ambient Thermal Resistance	80	°C/W

6415B-02.TBL

ELECTRICAL CHARACTERISTICS

$T_A = 25^{\circ}\text{C}$, $V_{CC} = 10\text{V}$, $R_{LOAD} = 10\text{k}\Omega$, $C_{LOAD} = 3\text{pF}$ (unless otherwise specified)

Symbol	Parameter	Min.	Typ.	Max.	Unit
V_{CC}	Supply Voltage (pin 9)	8	10	11	V
I_{CC}	Power Supply Current (without load on outputs ; $V_{CC}=10\text{V}$)	20	30	40	mA

INPUTS

	Maximum Signal Amplitude (CVBS signal)	2			V_{PP}
	Input Current (per output connected, input voltage = $5V_{DC}$) (this current is X6 when all outputs are connected on the input)		1	3	μA
	DC Level	3.3	3.6	3.9	V
	DC Level Shift (temperature from 0 to 70°C)		5	100	mV

OUTPUTS ($V_{IN} = 1V_{PP}$ for all dynamic tests) Pins 13 - 14 - 15 - 16 - 17 - 18

	Dynamic	4.5	5.5		V_{PP}
	Output Impedance		25	50	Ω
	Gain	5.5	6.5	7.5	dB
	Bandwidth ● -1dB attenuation ● -3dB attenuation	7	10 15		MHz MHz
	Crosstalk (f = 5MHz)		-50		dB
	DC level	2.4	2.7	3	V

I²C BUS INPUT : DATA, CLOCK, PROG (Pins 2 - 4 - 7)

	Threshold Voltage	1.5	2	3	V
--	-------------------	-----	---	---	---

6415B-03.TBL

GENERAL DESCRIPTION

The main function of the IC is to switch 8 video input sources on 6 outputs.

Each output can be switched on only one of each input. On each input an alignment of the lowest level of the signal is made (bottom of synch. top for CVBS or black level for RGB signals).

Each nominal gain between any input and output is 6.5dB. For D2MAC or Chroma signal the alignment is switched off by forcing, with an external resistor bridge, $5 V_{DC}$ on the input. Each input can be used as a normal input or as a MAC or Chroma

input (with external resistor bridge). All the switching possibilities are changed through the BUS.

Driving 75Ω load needs an external transistor.

It is possible to have the same input connected to several outputs.

The starting configuration upon power on (power supply : 0 to 10V) is undetermined.

In this case, 6 words of 16 bits are necessary to determine one configuration. In other case, 1 word of 16 bits is necessary to determine one configuration.

TEA6415B

BUS SELECTIONS (I²C-BUS)

2nd byte of transmission

ADDRESS MSB	DATA LSB	Selected Output	
00000	XXX	Pin 18	Output is selected by address bits
00100	XXX	Pin 14	
00010	XXX	Pin 16	
00110	---	Not used	
00001	XXX	Pin 17	
00101	XXX	Pin 13	
00011	XXX	Pin 15	
00111	---	Not used	
		Selected Input	
00XXX	000	Pin 5	Input is selected by data bits
00XXX	100	Pin 8	
00XXX	010	Pin 3	
00XXX	110	Pin 20	
00XXX	001	Pin 6	
00XXX	101	Pin 10	
00XXX	011	Pin 1	
00XXX	111	Pin 11	

Example :00100 101 connects pin 10 (input) to pin 14 (output) (equals 25 in hexadecimal)
Address byte (1st byte of transmission)

86	1000	0110
06	0000	0110

When pin PROG is connected to ground

When pin PROG is connected to V_{CC}

IN / OUT PIN CONFIGURATION

Figure 1 : Input Configuration

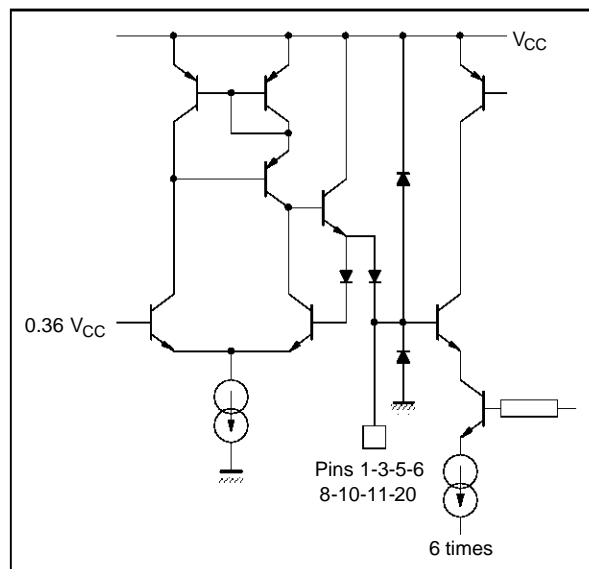
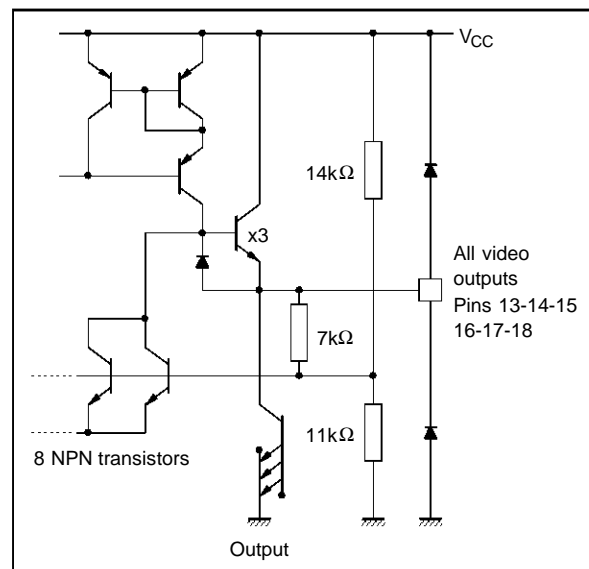

Figure 2 : Output Configuration



IN / OUT PIN CONFIGURATION (continued)

Figure 3 : Bus I/O Configuration

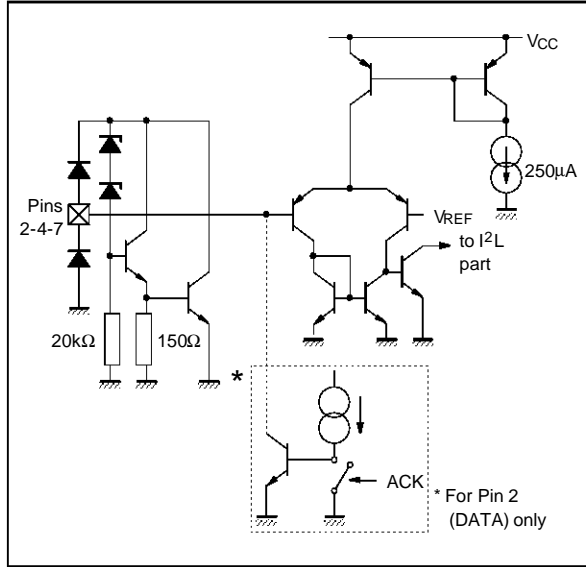
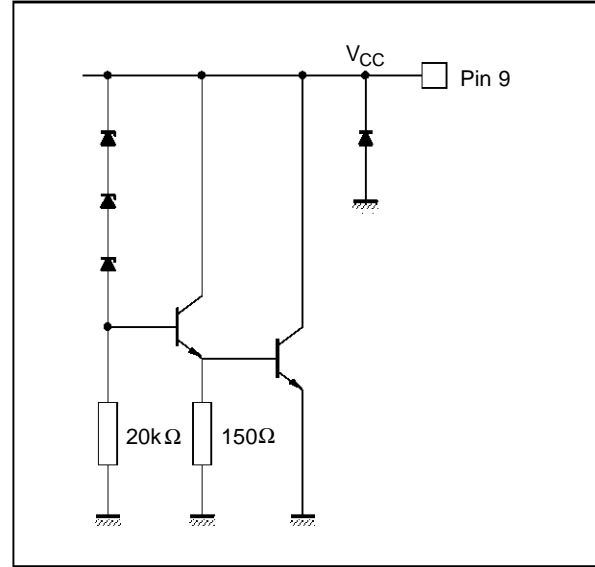

Figure 4 : VCC Pin Configuration



USE WITH AN OTHER TEA6415B

The programming input (PROG) permits to operate with two TEA6415B in parallel and to select them independantly through the I²C-BUS without

modifying the adress byte. Consequently, the switch capabilities are doubled or IC1 and IC2 can be cascaded.

Figure 5

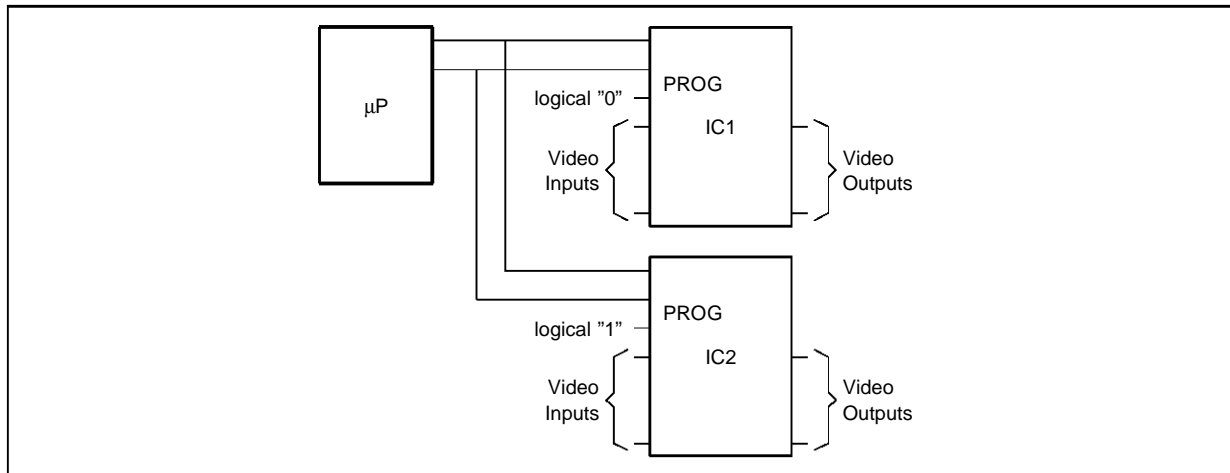

TYPICAL APPLICATION

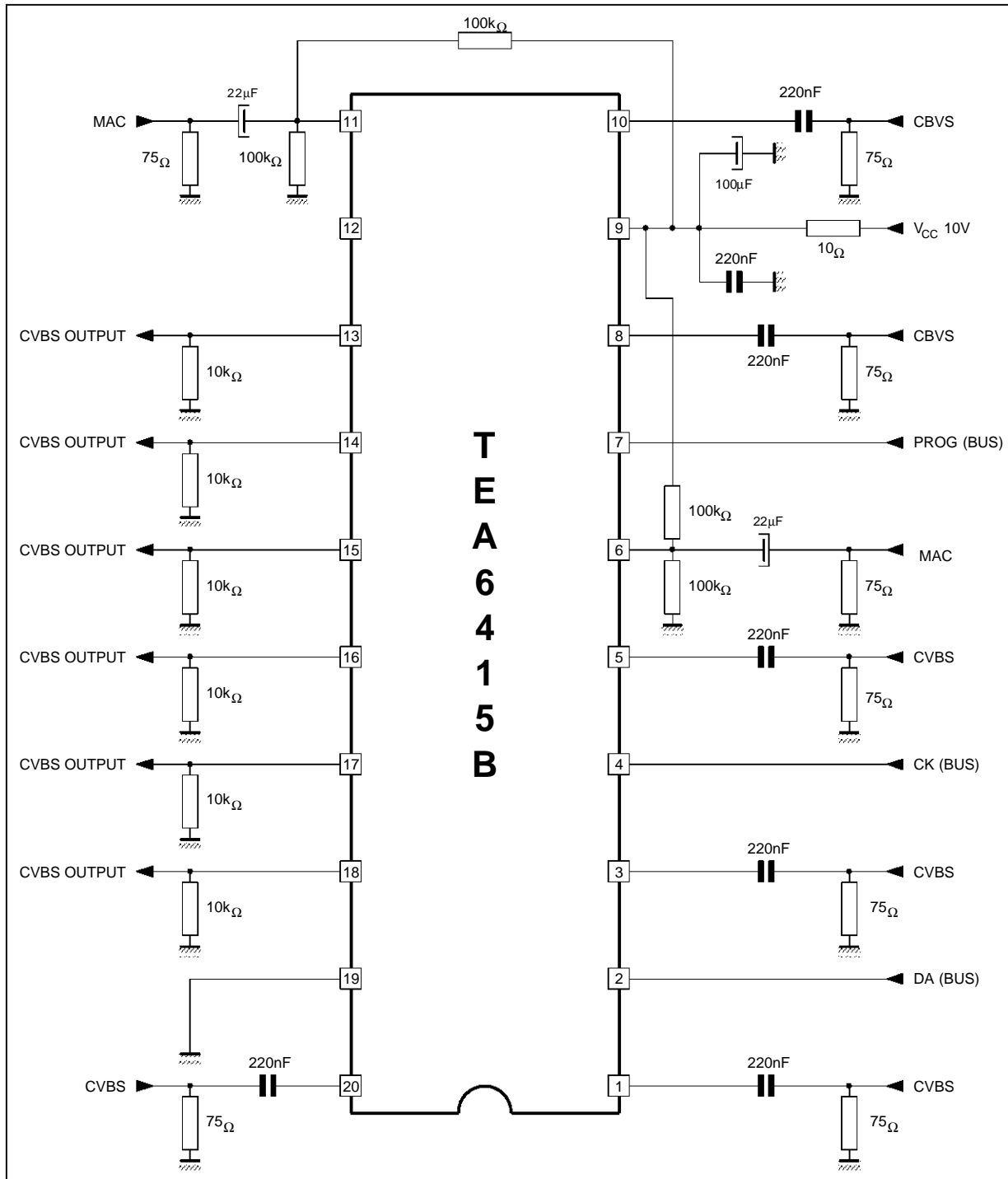

6415B-08.EPS

CROSSTALK IMPROVEMENT

1 - When any input is not used, it must be bypassed to ground through a 220nF capacitor.

2 - An important improvement can be achieved considering the input crosstalk by means of the application (see technical note).

OTHER APPLICATION DIAGRAM EXAMPLE

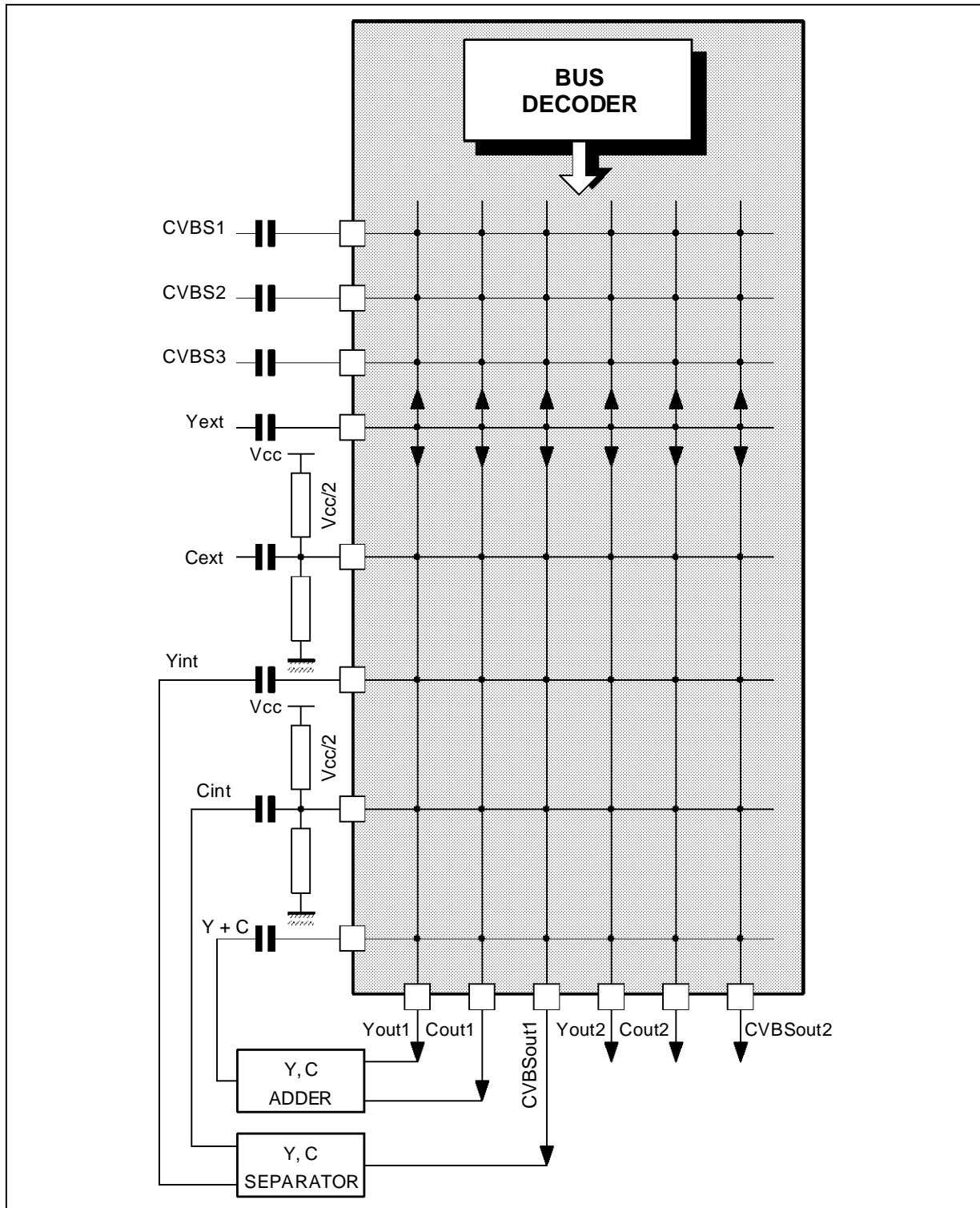

6415B-09.EPS

TEA6415B

PACKAGE MECHANICAL DATA

20 PINS – PLASTIC DIP

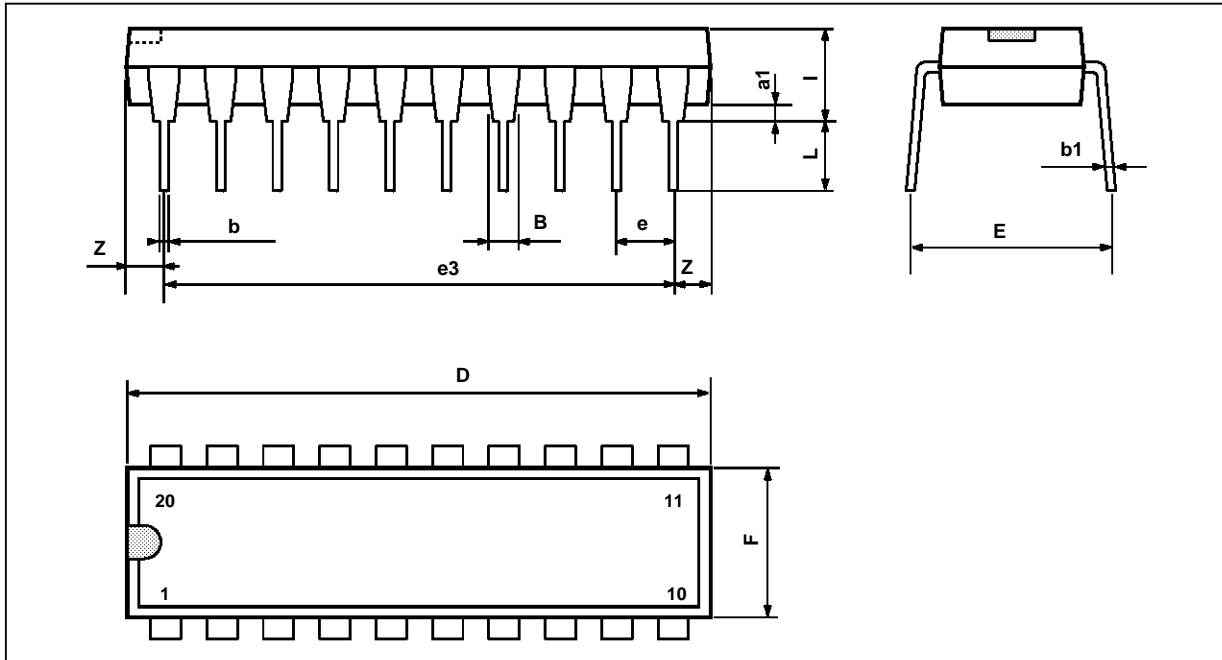

PM-DIP20.EPS

Dimensions	Millimeters			Inches		
	Min.	Typ.	Max.	Min.	Typ.	Max.
a1	0.254			0.010		
B	1.39		1.65	0.055		0.065
b		0.45			0.018	
b1		0.25			0.010	
D			25.4			1.000
E		8.5			0.335	
e		2.54			0.100	
e3		22.86			0.900	
F			7.1			0.280
i			3.93			0.155
L		3.3			0.130	
Z			1.34			0.053

DIP20.TBL

Information furnished is believed to be accurate and reliable. However, SGS-THOMSON Microelectronics assumes no responsibility for the consequences of use of such information nor for any infringement of patents or other rights of third parties which may result from its use. No licence is granted by implication or otherwise under any patent or patent rights of SGS-THOMSON Microelectronics. Specifications mentioned in this publication are subject to change without notice. This publication supersedes and replaces all information previously supplied. SGS-THOMSON Microelectronics products are not authorized for use as critical components in life support devices or systems without express written approval of SGS-THOMSON Microelectronics.

© 1994 SGS-THOMSON Microelectronics - All Rights Reserved

Purchase of I²C Components of SGS-THOMSON Microelectronics, conveys a license under the Philips I²C Patent. Rights to use these components in a I²C system, is granted provided that the system conforms to the I²C Standard Specifications as defined by Philips.

SGS-THOMSON Microelectronics GROUP OF COMPANIES

Australia - Brazil - China - France - Germany - Hong Kong - Italy - Japan - Korea - Malaysia - Malta - Morocco
The Netherlands - Singapore - Spain - Sweden - Switzerland - Taiwan - Thailand - United Kingdom - U.S.A.